

Counting Efficiency for Rapid Preparation of Known Amounts of ^{222}Rn by the Air Luminescence Method

Yuko Morita-Murase,* Isao Murakami, and Yoshio Homma

Laboratory for Physical Chemistry, Kyoritsu College of Pharmacy,
1-5-30, Shibakoen, Minato-ku, Tokyo 105 Japan

Received: June 17, 2003; In Final Form: December 19, 2003

The counting efficiency for air luminescence due to ^{222}Rn and its daughters was determined with commercially available liquid scintillation spectrometers giving much attention to Cherenkov radiation due to β^- -particles and internal conversion electrons from ^{214}Pb and ^{214}Bi . Based on the results, we propose a rapid and reliable method for preparation of known amounts of ^{222}Rn , which are needed for calibration of detectors measuring ^{222}Rn or a number of experiments using ^{222}Rn , without elaborate instrumentation or technique.

1. Introduction

The preparation of known amounts of ^{222}Rn is a problem common to many fields of research dealing with ^{222}Rn . Until now, known amounts of ^{222}Rn were prepared by collecting ^{222}Rn from a standard ^{226}Ra source and determining the amounts based on the secular equilibrium between ^{226}Ra and ^{222}Rn . In order to collect accurate amounts of ^{222}Rn by this method, it is indispensable to verify experimentally that all or a fixed fraction of ^{222}Rn from a standard ^{226}Ra source is removed and collected. In addition, the method requires a long waiting period (15–30 days) to grow ^{222}Rn from the source. The need for a simple and reliable method for the preparation of known amounts of ^{222}Rn has become apparent.

In previous papers,^{1–3} the present authors determined several α -emitters including ^{222}Rn by measuring the luminescence counts from excited nitrogen⁴ with a liquid scintillation spectrometer (LSS) and proposed a method for determining ^{222}Rn using the air luminescence method (ALM). However, the reported counting efficiency of the ALM for ^{222}Rn and its daughters (^{218}Po , ^{214}Pb , ^{214}Bi , and ^{214}Po) was determined with a specially modified LSS which could not be universally utilized:¹ the pulses from the sum circuit of the LSS (Model 6880, Tracor Analytic) were fed into an amplifier and then to a 1024-channel pulse-height analyser. Therefore, the counting efficiency of air luminescence due to ^{222}Rn and its daughters was determined with LSSs by use of known amounts of ^{222}Rn which were standardized by measuring γ -rays from ^{214}Pb with a Ge well detector. Much attention was also given to Cherenkov counting efficiency due to β^- -particles from ^{214}Pb and ^{214}Bi and the counting efficiency for the short-lived daughters,⁵ some of which were assumed to be attached to the wall of the counting vial for LSS.⁶

In the present study, the counting efficiencies of air luminescence due to ^{222}Rn and its daughters were determined for several LSSs. Based on the counting efficiencies obtained, we offer a simple, rapid and reliable method for preparing known amounts of ^{222}Rn without elaborate instrumentation and technique. Some significant advantages of the proposed method are that the time required for the preparation of known amounts of ^{222}Rn is only 3.5 h, and that the ^{226}Ra source, from which ^{222}Rn is collected, does not necessarily have to be a standardized one, because we do not determine ^{222}Rn based on the

secular equilibrium between ^{226}Ra and ^{222}Rn . We can obtain known amounts of ^{222}Rn simply by measuring ^{222}Rn that is actually transferred and stored in the counting vial. Therefore, we need not verify that all of the ^{222}Rn from the ^{226}Ra source was removed and collected. Disadvantages of the conventional method for preparing known amounts of ^{222}Rn are also discussed in some detail.

Exactly, the luminescence in this study should be termed “nitrogen luminescence”. However, “air luminescence” was employed in conformity with the expression used in the previous papers.^{1–3,7}

2. Experimental

^{222}Rn Sample. One hundred milliliters of ^{226}Ra solution ($^{226}\text{RaCl}_2$ in 0.1 M HCl) was enclosed in a 200 mL flask with a rubber stopper. ^{222}Rn was collected from the air space above the $^{226}\text{RaCl}_2$ solution with a syringe and added to air in a quartz tube of 0.7 cm internal diam and 4 cm long, both ends of which were closed with silicone rubber stoppers (Figure 1), yielding a volume of 1.15 cm³. ^{222}Rn in the tube was allowed to remain for 3.5 h before measurement. During the time,

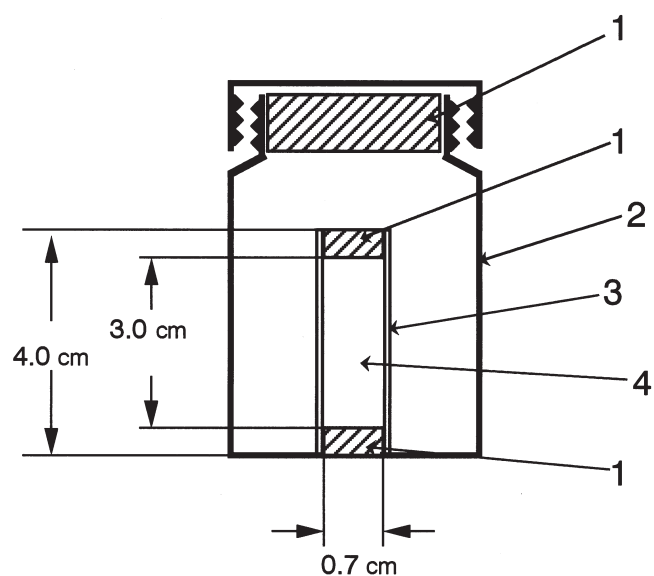

Figure 1. Schematic diagram of the ^{222}Rn sample and the counting vial for measuring the counting efficiency of the air luminescence method: 1. silicone rubber stopper; 2. counting vial; 3. quartz tube; 4. ^{222}Rn sample.

*Corresponding author. E-mail: murase-yk@kyoritsu-ph.ac.jp.
FAX: +81-3-5400-2685.

^{218}Po , ^{214}Pb , ^{214}Bi , and ^{214}Po came to transient equilibrium with ^{222}Rn .

Measurements. The radioactivity of ^{222}Rn was determined through its daughter ^{214}Pb by measuring γ -rays from ^{214}Pb with a well type Ge detector (Model GCW1521, Canberra Industries). This system had a 1.9 keV resolution (FWHM) at 1.33 MeV and relative efficiency of 17.1%.

The full energy peak efficiency of the Ge detector was obtained by measuring two types of γ -ray standard sources: the EGP type γ -ray standard sources of ^{57}Co , ^{60}Co , and ^{137}Cs (LMRI, France), and the standard solutions of ^{131}I and ^{203}Hg (AEA Technology Quality and Safety Assurance, Harwell, UK). The energy and abundance of the γ -rays used were: ^{57}Co (0.122 MeV, 85.60%), ^{60}Co (1.173 MeV, 99.90% and 1.333 MeV, 99.98%), ^{137}Cs (0.662 MeV, 85.1%), ^{131}I (0.364 MeV, 81.1%), and ^{203}Hg (0.279 MeV, 81.46%).⁸

The EGP type γ -ray standard source, the point source which is attached to an end of a plastic rod, was mounted at every 0.25 cm along the axial line of the well of the Ge detector between positions P_1 and P_2 (Figure 2) and counted for 5 min each. By averaging the results obtained for EGP type source, the full energy peak efficiencies for the γ -emitters, which are assumed to be uniformly distributed in the quartz tube, can be calculated.

The standard solution (^{131}I or ^{203}Hg) was transferred into a quartz tube, which is identical to that for the ^{222}Rn sample, and mounted in the well of the Ge detector and counted for 5 min.

The energy and abundance of γ -ray from ^{214}Pb used for the determination were 0.352 MeV and 35.85%, respectively.⁸ The full energy efficiencies obtained for the γ -ray standard sources gave a straight line on log-log scale in the energy range of 0.279 MeV to 1.333 MeV (Figure 3). The equation fitted to the linear part of the experimental data in Figure 3, which was calculated by a least squares method, is given by

$$\log Y = -1.029 \log X + 0.8597 \quad (1)$$

where Y is the full energy peak efficiency expressed in percent and X is the γ -ray energy expressed in MeV. Thus, the full energy peak efficiency for 0.352 MeV γ -ray was estimated to be $(21.2 \pm 0.4)\%$.

The full energy peaks of ^{214}Pb were counted at least 1800 counts to limit the statistical error to less than 2.4%. The dead time losses were always less than 1%. No peaks which seem to be due to sum effects were observed. Thus, ^{222}Rn in the quartz tube was standardized based on the ^{214}Pb activity.

The background of LSS was determined by measuring a

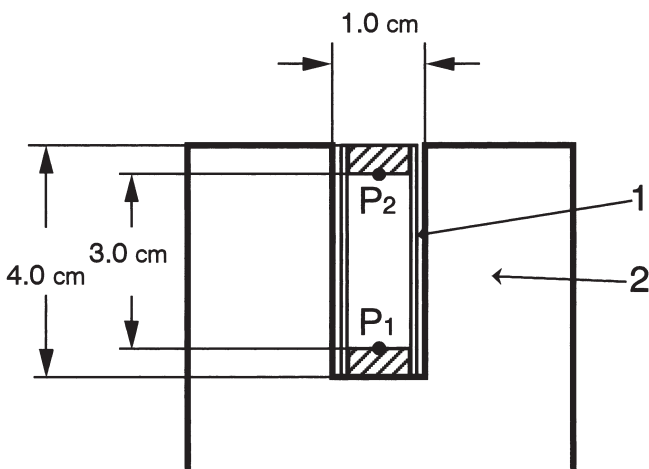

Figure 2. The position of the EGP type point source in the well of Ge detector for the determination of the full energy peak efficiency: 1. quartz tube; 2. Ge well detector; P_1 , the position on the center line of the well at 0.5 cm from the lower end of the tube; P_2 , the position on the center line of the well at 0.5 cm from the upper end of the tube.

liquid scintillation counting vial, which was full of air and sealed with air-tight cap. The background sample was allowed to remain for ca. 60-days before measurement. Consequently, ^{222}Rn and its daughters in the background sample, if present, could be almost completely decayed. The background was observed to be constant within statistical error.

After the γ -ray spectrometric determination of ^{222}Rn , the quartz tube containing ^{222}Rn and its daughters was put in the liquid-scintillation-counting vial and, after sealing with a silicone rubber stopper, the counting vial was shaken until the quartz tube in the vial was broken. The sample which contains the equilibrium mixture of ^{222}Rn and its daughters is hereinafter referred to as the "standard ^{222}Rn sample". Table 1 lists the standard ^{222}Rn samples containing a wide variety of ^{222}Rn prepared in a similar manner as described above. It has to be stated here that determination of low-level ^{222}Rn samples with a Ge well detector is impractical because it requires a rather long counting period, although it is a method of choice for a limited number of samples. The air luminescence counts of the standard ^{222}Rn samples were measured with LSSs for 30 min (Table 1).

3. Results and Discussion

The counting efficiency (ϵ_α) of the standard ^{222}Rn sample obtained by ALM is given by the relation

$$\epsilon_\alpha = [A_{\text{air}} (\text{cps}) / S (\text{Bq})] \times 100\%, \quad (2)$$

where A_{air} is the air luminescence count rate of the standard ^{222}Rn sample and S is the total disintegration rate of the standard ^{222}Rn sample, *i.e.*, the total disintegration rate of ^{222}Rn and its daughters.

It is noted that the total disintegration rate of the standard ^{222}Rn sample is 5 times the activity of ^{222}Rn . Table 1 lists the total disintegration rates of the standard ^{222}Rn samples and the counting efficiencies by the ALM for several LSSs. The average counting efficiency was calculated based on the weighting factor, which is inversely proportional to the standard deviation of individual ϵ_α .

The counting efficiencies are in the range of 21.5% to 45.8%, because the counting efficiency by the ALM is a function of the optical properties of the system (*e.g.*, optical coupling, light collection, reflection), the properties of the photomultiplier tubes (quantum efficiency, multiplication, spectral response), and the properties of the electronic circuit.

The air luminescence counts of the standard ^{222}Rn samples

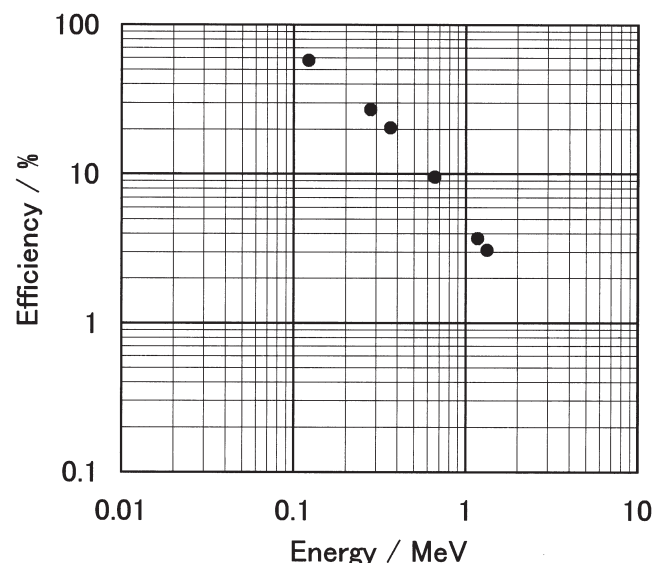

Figure 3. Full energy peak efficiencies as a function of γ -ray energy.

TABLE 1: The Counting Efficiencies of the ALM, ϵ_α , for Several LSSs

LSS	S/Bq	$\epsilon_\alpha/\%$	LSS	S/Bq	$\epsilon_\alpha/\%$
Aloka	3281.25 ± 2.15	42.57 ± 0.15	Beckman	5038.63 ± 9.93	44.33 ± 0.12
LSC-3500	2636.99 ± 1.67	43.72 ± 0.15	LS5801	3751.33 ± 8.57	44.37 ± 0.14
	946.11 ± 0.64	41.41 ± 0.16		1602.04 ± 3.54	46.14 ± 0.14
	665.30 ± 0.54	42.42 ± 0.20		1025.78 ± 1.42	46.91 ± 0.09
	345.61 ± 0.34	43.40 ± 0.26		629.96 ± 2.23	44.94 ± 0.22
	152.45 ± 0.16	42.96 ± 0.32		76.54 ± 0.39	46.25 ± 0.32
	51.26 ± 0.10	43.15 ± 0.57		12.27 ± 0.17	46.95 ± 0.92
	32.83 ± 0.09	41.88 ± 0.67		3.47 ± 0.11	46.74 ± 2.07
	14.77 ± 0.07	41.92 ± 1.14			av. 45.70 ± 0.05 ^b
		av. 42.67 ± 0.07 ^b			
Aloka	3088.23 ± 3.48	38.66 ± 0.11	Beckman	1277.35 ± 2.24	45.88 ± 0.11
LSC-6100 ^a	1504.17 ± 2.43	37.92 ± 0.11	LS6000	592.16 ± 1.53	45.61 ± 0.16
	460.71 ± 1.35	38.16 ± 0.20		441.34 ± 1.32	44.09 ± 0.18
	45.08 ± 0.43	38.46 ± 0.65		361.20 ± 1.19	46.11 ± 0.21
		av. 38.28 ± 0.07 ^b		243.68 ± 0.98	46.65 ± 0.26
				112.47 ± 0.67	44.61 ± 0.38
				46.00 ± 0.43	44.22 ± 0.58
					av. 45.57 ± 0.07 ^b
Packard	1405.87 ± 2.35	21.02 ± 0.06	Beckman	1277.35 ± 2.24	43.87 ± 0.11
Tri-Carb 3170TR/SL	1042.35 ± 2.02	21.51 ± 0.07	LS6500	592.16 ± 1.53	43.43 ± 0.16
(Normal Level Count Mode)	751.60 ± 1.72	21.93 ± 0.08		441.34 ± 1.32	42.23 ± 0.18
	291.43 ± 1.07	21.69 ± 0.14		361.20 ± 1.19	43.69 ± 0.20
	181.28 ± 0.84	21.65 ± 0.18		243.68 ± 0.98	44.60 ± 0.25
	72.52 ± 0.54	21.43 ± 0.27		112.47 ± 0.67	42.75 ± 0.36
		av. 21.43 ± 0.04 ^b		46.00 ± 0.43	42.96 ± 0.58
					av. 43.52 ± 0.07 ^b

^a window setting: 0.05–1000 keV^b weighted average**TABLE 2: The Counting Efficiency of the ALM, ϵ_α , Measured with the LLCM of the Tri-Carb 3170TR/SL**

LSS	S/Bq	$\epsilon_\alpha/\%$
Packard	1405.87 ± 2.35	3.32 ± 0.02
Tri-Carb 3170TR/SL	1042.35 ± 2.02	3.34 ± 0.02
(Low Level Count Mode)	751.60 ± 1.72	3.35 ± 0.03
	291.43 ± 1.07	3.47 ± 0.05
	181.28 ± 0.84	3.38 ± 0.06
	72.52 ± 0.54	3.61 ± 0.10
		av. 3.35 ± 0.01 ^a

^a weighted average

were also measured with the low level counting mode (LLCM) of the Tri-Carb LSS (3170TR/SL) (Table 2). The LLCM of the instrument excludes most of the pulses which are not produced in the liquid scintillator (LS). The use of the LLCM for measuring the air luminescence counts is impractical, because air luminescence counts are not produced in the LS. However, it must be emphasized that when the standard ^{222}Rn samples were measured with the normal counting mode of the instrument, rather practical counting efficiency for the air luminescence was obtained (Table 1).

As has been reported in the previous papers,^{1–3} ϵ_α measured in this way is the sum of the following three counting efficiencies:

$$\epsilon_\alpha = \epsilon_u + \epsilon_a + \epsilon_c, \quad (3)$$

where ϵ_u is the counting efficiency for α -emitters which are uniformly distributed in the air in the counting vial and do not attach to the wall of the counting vial (unattached daughters), ϵ_a is the counting efficiency for α -emitters which are attached to the wall of the counting vial, and ϵ_c is the Cherenkov counting efficiency due to β^- -particles from ^{214}Pb and ^{214}Bi in

the counting vial.

Determination of ϵ_u , ϵ_a , and ϵ_c for an Aloka LSS have been reported.⁶ The results can be summarized as follows: The value of ϵ_u was determined by measuring the air luminescence counts due to α -particles from a standardized ^{210}Po source (which was electroplated on a silver disc) at different positions in the counting vial with the LSS.

$$\epsilon_u = (\text{the air luminescence count rate/the } \alpha\text{-emission rate}) \times 100\%. \quad (4)$$

In spite of the different positions of the source in the counting vial, the measured counting efficiencies showed good agreement with each other, and ϵ_u could reasonably be taken as the average of those values, *i.e.*, $(67.5 \pm 0.4)\%$. On the other hand, a part of the short-lived daughters of ^{222}Rn seem to be attached to the wall of the counting vial and are supposed to be counted with 2π geometry. Therefore, ϵ_a is ca. $(1/2) \times (67.5 \pm 0.4) = (33.8 \pm 0.2)\%$. It is noted that the β^- -emitters do not produce an air luminescence count and that ^{222}Rn , which has a relatively long half-life (3.82 d), is assumed to be unattached to the wall of the counting vial. Beta-particles from ^{214}Pb (av. $E_{\beta^-} = 0.220$ MeV)⁹ and ^{214}Bi (av. $E_{\beta^-} = 0.641$ MeV)⁹ in the counting vial gave off Cherenkov radiation by interacting with the wall of the counting vial, and gave additional count rates. In order to determine ϵ_c , we prepared and standardized a variety of β^- -emitters and radionuclides which emit internal conversion electrons, and measured the Cherenkov radiation with the Aloka LSS. The values of ϵ_c , which are plotted as functions of the average energy of β^- -particles and the internal conversion electrons, gave a straight line on the log-log scale. Based on the results, the values of ϵ_c for ^{214}Pb and ^{214}Bi were found to be $(3.7 \pm 0.2)\%$ and $(32.9 \pm 1.3)\%$, respectively.⁵ Cherenkov radiation may also be produced if the energy of photoelectron and Compton electrons due to γ -rays is greater than the threshold energy of a medium, *e.g.*, the glass wall of the

counting vial and glass components of the detection system. Therefore, we also measured the Cherenkov counting efficiencies due to γ -rays from ^{214}Pb and ^{214}Bi , and these were estimated to be $(0.003 \pm 0.001)\%$ and $(0.088 \pm 0.003)\%$, respectively.⁵ The Cherenkov counting efficiencies described above were corrected for those due to γ -rays, details of which were reported elsewhere.⁵

Based on the values of ϵ_α , ϵ_u , ϵ_a , and ϵ_c , the average ratio of the number of the daughters of ^{222}Rn which are attached to the wall to the total number of the daughters was determined to be $(38.7 \pm 2.8)\%$. The ratio obtained in this study is important because it gives information about adsorption of short-lived daughters of ^{222}Rn in a small container such as a counting vial. More extensive experiments would be desirable to determine the concentration of the short-lived daughters in various containers and indoor air, which will be of value for the determination of the equilibrium factor, the ratio of the equilibrium equivalent concentration and the ^{222}Rn gas concentration.

It must be emphasized that only ϵ_α is required in actual preparation and determination of ^{222}Rn , and that environmental ^{222}Rn concentrations obtained by this method are in good agreement with those obtained by other independent methods using the PICO-RADTM cartridge and track detector.¹⁰

Over the years it has been established, in far too many reports to list here, that known amounts of ^{222}Rn can be prepared by collecting ^{222}Rn from a standard ^{226}Ra source and determined based on the secular equilibrium between ^{226}Ra and ^{222}Rn . However, it seems relatively certain that the conventional method for preparing ^{222}Rn has several disadvantages:

- (1) In most cases, a long waiting period (15–30 days) is required to grow ^{222}Rn from a standard ^{226}Ra source.
- (2) In most reports, it was not confirmed experimentally that all of the ^{222}Rn from the standard ^{226}Ra source is removed and transferred to the intended equipment, although it is of great importance for the preparation of an accurate amount of ^{222}Rn . This seems mainly due to the fact that, at the instant immediately after the removal of ^{222}Rn , measurements of trace amounts of ^{222}Rn which might be left in the standard ^{226}Ra source would be difficult.
- (3) Arbitrary amounts of ^{222}Rn , which are independent of the activity of the standard ^{226}Ra source, cannot be obtained.
- (4) Most of the methods for the preparation of ^{222}Rn require specialized equipment for handling ^{222}Rn . The preparation method should be simple to permit measurement by routine counting instruments.
- (5) The instrument for the determination of ^{222}Rn suffers from the ready deposition of the daughter products on its inner surface, which produces a background “memory effect” and makes accurate measurements of low-level ^{222}Rn difficult.

On the other hand, the advantages of the ALM are, we think, readily apparent. These include:

- (1) The time required for the preparation of known amounts of

^{222}Rn is only 3.5 h.

- (2) The ^{226}Ra solution, from which ^{222}Rn is collected, does not necessarily have to be a standard one, because we do not determine ^{222}Rn based on the secular equilibrium between ^{226}Ra and ^{222}Rn . Known amounts of ^{222}Rn can be obtained simply by measuring the air luminescence count of ^{222}Rn that is actually transferred and stored in the counting vial. Consequently, we need not confirm that all of the ^{222}Rn from the ^{226}Ra solution was transferred.
- (3) Arbitrary amounts of ^{222}Rn necessary for a variety of experiments can be obtained by adding standard ^{222}Rn samples of various activities.
- (4) The ALM is simple to permit measurement by a commercially available LSS and does not require special equipment for handling ^{222}Rn .
- (5) The ALM is free from the memory effect, because the deposition of the daughter nuclides of ^{222}Rn on the LSS is prevented.

In closing, it should be pointed out that the obtained counting efficiency, ϵ_α , is based on an experimental technique and does not depend on any theoretical calculations. It can be determined in the same manner as described above and applied to rapid and reliable determination of known amounts of ^{222}Rn .

Acknowledgements. The authors wish to express their appreciation to Ms. Etsuko Furuta of Ochanomizu University, and Dr. Yukio Yoshizawa and Dr. Makoto Takiue of The Jikei University School of Medicine for the use of their apparatuses and for their help.

References

- (1) Y. Homma, Y. Murase, and M. Takiue, *J. Radioanal. Nucl. Chem. Lett.* **119**, 457 (1987).
- (2) Y. Murase, Y. Homma, M. Takiue, and T. Aburai, *Appl. Radiat. Isot.* **40**, 291 (1989).
- (3) Y. Murase, Y. Homma, and M. Takiue, *Appl. Radiat. Isot.* **40**, 295 (1989).
- (4) S. Dondes, P. Harteck, and C. Kunz, *Radiat. Res.* **27**, 174 (1966).
- (5) Y. Morita-Murase, I. Murakami, and Y. Homma, *Chem. Lett.* **30**, 1158 (2000).
- (6) Y. Morita-Murase, I. Murakami, and Y. Homma, *Chem. Lett.* **31**, 238 (2001).
- (7) M. Takiue and H. Ishikawa, *Nucl. Instr. and Meth.* **159**, 139 (1979).
- (8) R. B. Firestone and V. S. Shirley, *Table of Isotopes*, 8th ed., John Wiley & Sons, New York (1996).
- (9) E. Browne and R. B. Firestone, *Table of Radioactive Isotopes*, John Wiley & Sons, New York (1986).
- (10) Y. Murase, Y. Homma, I. Murakami, K. Handa, and K. Horiuchi, *Appl. Radiat. Isot.* **50**, 561 (1999).